

Solid constructure by aluminum die-cast case.

■ Features

- High speed response time : 1mS
- Built-in short circuit protection.
- Built-in protection circuit for reversing connection.
- Strong constructure by aluminum die-cast case.



■ Ordering information

Type	Detecting distance	Model	Operating voltage	Operating mode	Output
Through 	30mm 	BUD-30	DC	Selectable Light ON/ Dark ON by cable wire	NPN open collector
		BUD-30S			
	50mm 	BUD-50			
		BUD-50S			

■ Specification

Model	BUD-30	BUD-30S	BUD-50	BUD-50S
Detecting target	Opaque materials of Min. ϕ 4mm	Opaque materials of Min. ϕ 1.5mm	Opaque materials of Min. ϕ 4mm	Opaque materials of Min. ϕ 1.5mm
Detecting mode	Selectable Light ON or Dark ON by cable wire			
Detecting distance	30mm		50mm	
Response time	Max. 1mS			
Power supply	12 to 24VDC \pm 10% (ripple P-P:Max. 10%)			
Power consumption	Max. 30mA			
Source of light	Infrared LED			
Sensitivity	Fixed	Adjustable	Fixed	Adjustable
Control output	●NPN open collector output load voltage Max. 30V, load current Max. 200mA, residual voltage Max. 2V			
Protection circuit	Short-circuit protection, Reverse polarity protection			
Indicator	Operating indicator : red LED, Voltage indicator : green LED			
Connection	Cable connection			
Insulation resistance	Min. 20M Ω (500VDC)			
Noise strength	Power line \pm 240V at pulse band 1 μ s of noise simulation			
Dielectric strength	500VAC 50/60Hz for 1minute			
Vibration	1.5mm amplitude at frequency of 10 to 55Hz in each of X,Y,Z directions for 2 hours			
Shock	500m/s ² (50G) in X,Y,Z directions for 3 times			
Ambient operating illumination	Sunlight:11,000 Lux. Max., Incandescent lamp:3,000 Lux. Max.			
Ambient temperature	Operating: -25 to 65 $^{\circ}$ C < BUD-30S/50S; -10 to 60 $^{\circ}$ C (non-freezing condition) > , Storage: -35 to 70 $^{\circ}$ C			
Humidity	35 to 85% RH, Storage:35 to 85% RH			
Structure of protection material	IP65(IEC specification) Case : ALDC12, PC			
Cable	3P, ϕ 4mm, length:2m			
Weight	About 110g		About 130g	

※The weight of above chart is net weight.

BUD SERIES

Control output circuit

○NPN open collector output

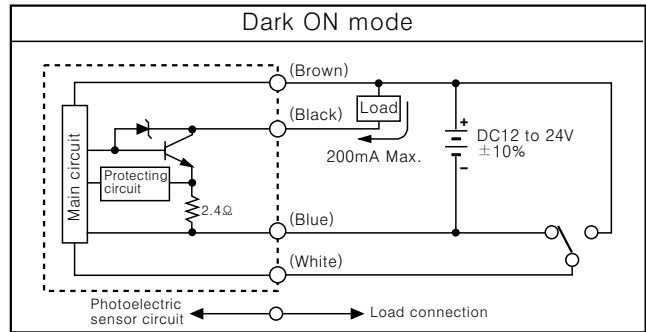
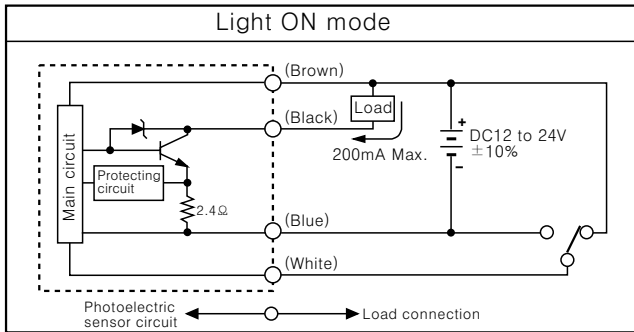

Operating mode and time chart

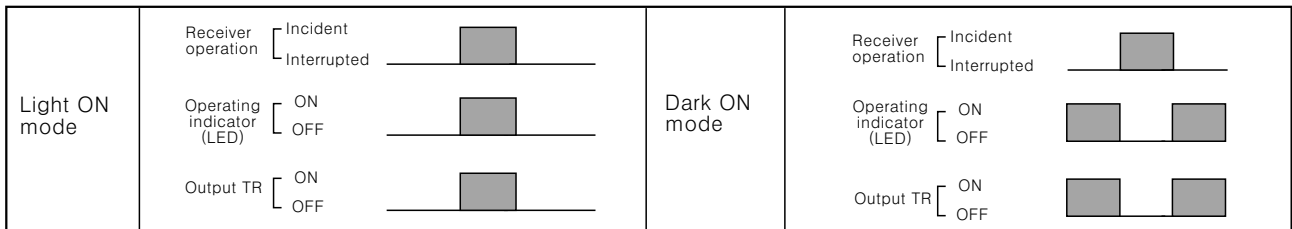

Connections

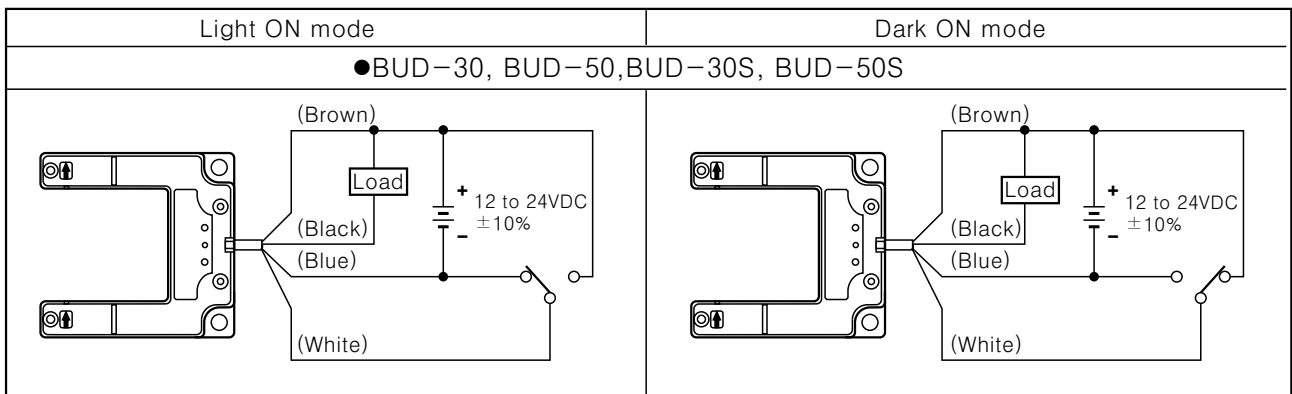

※ Non-using wires must be insulated.

Dimensions

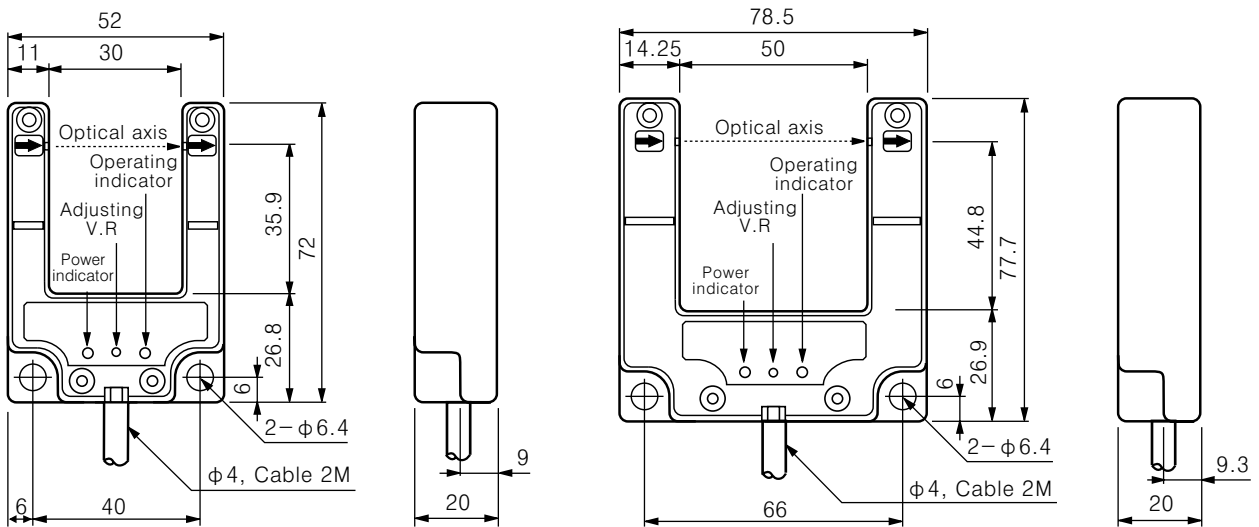

Unit:mm