

SENSOR CONTROLLER

■ Features

- Compact size & high quality.
- Free switching power voltage.
- Built-in time function.
- Contact input & solid-state input.
- DIN rail mounting.
- Selectable input & output by DIP switch.
- High input response.



■ Ordering information

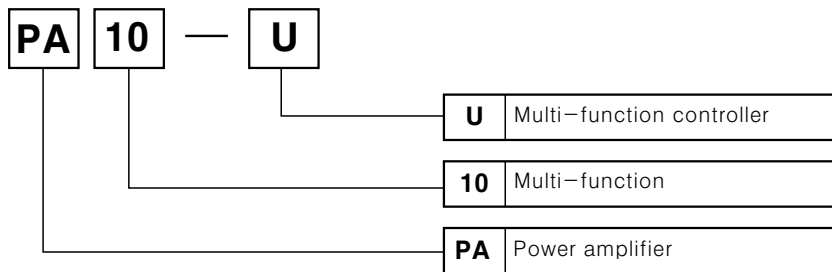

■ Specification

MODEL		PA10 - U
Power supply		100 to 240VAC ±10% 50/60Hz
Power consumption		100V AC 160Hz : approx. 7VAC under load regulation of DC12V/200mA 240V AC 160Hz : approx. 10VAC
Power for extrnal sensor		12VDC ±10% About 200mA
Input(IN1)(IN2)		Solid-state signal (NPN transistor)
(IN1)(IN2) input impedance		1.5KΩ
Output	Relay output	250VAC 3A(Resistive load), • Service life : mechanically 5,000,000 • Electrically : 100,000 operations
	O · C output	NPN open collector output Max. 30VDC 200mA
Response time		Relay contact : About 10mS, Transistor output : 50μs
Timer function	Have	Selectable ON-Delay, OFF-Delay, ONE-Shot Delay, FLICKER, FLICKER ONE-Shot, Low-Speed Detection, High-Speed Detection Selectable 0.01 to 0.1S, 0.1 to 1S, 1 to 10S ,10 to 100S
	non	• NORMAL • FLIP-FLOP • ENCODER (MODE 9 to 11)□
Dielectric strenth		2000VAC 50/60Hz for 1 minute (cutoff current = 0.5mA)
Insulation resistance		100MΩ (500VDC Mega)
Ambient operating temperature		-10 to +55℃ (Non-freezing condition)
Ambient stonge temperature		-25 to +60℃ (Non-freezing condition)
Ambient humidity		35 to 80%RH
Weight		About 150g

※The weight of above chart is net weight.

※If the load is connected over 200mA at the sensor output, it may occur unit trouble.

Dimension

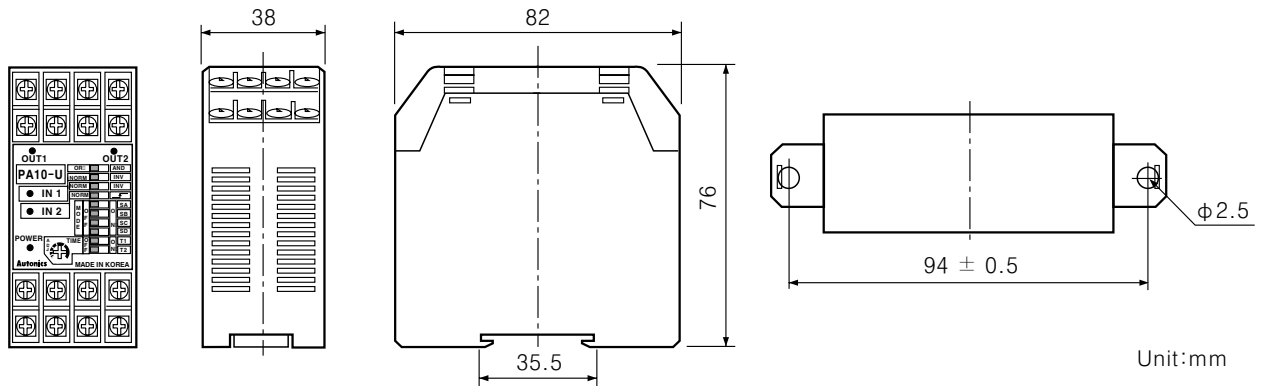

Connections

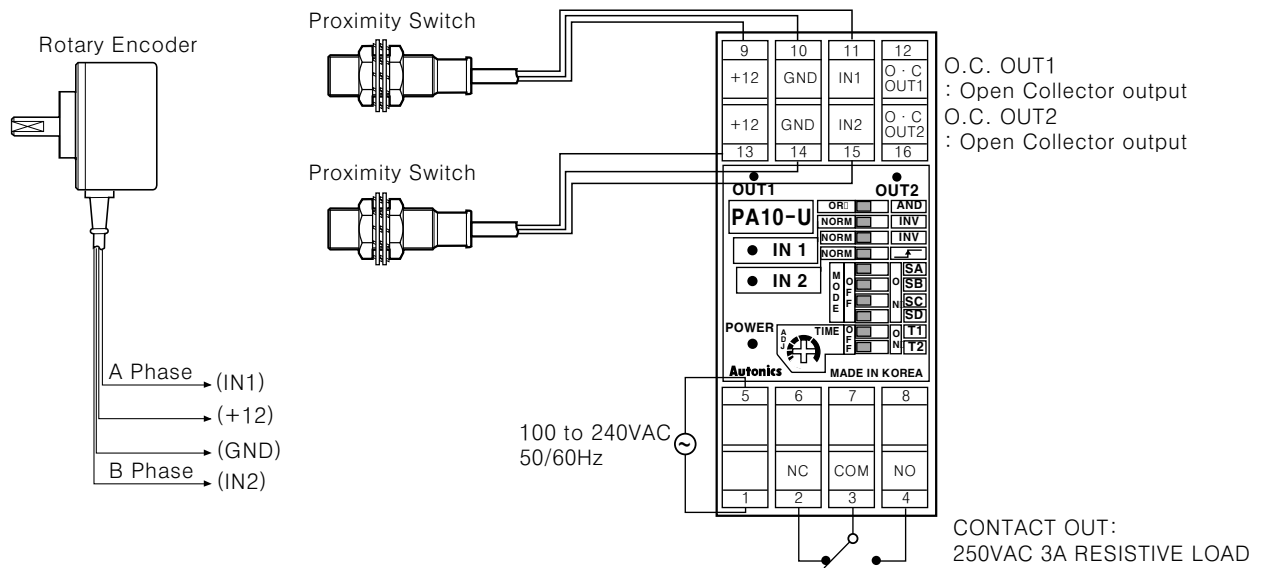

Input connection

● Open collector type sensor & NPN universal output type sensor

● Controller

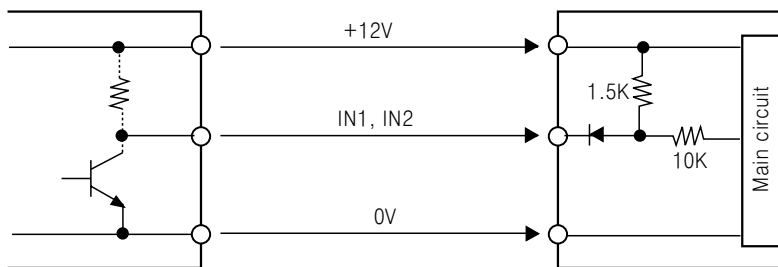

PA10-U

Output

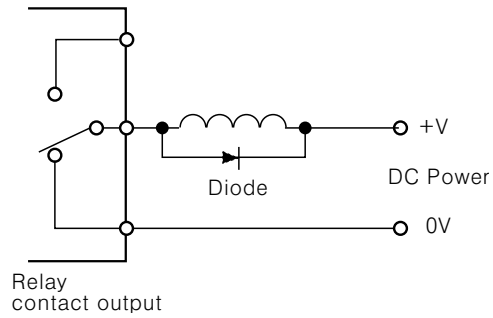
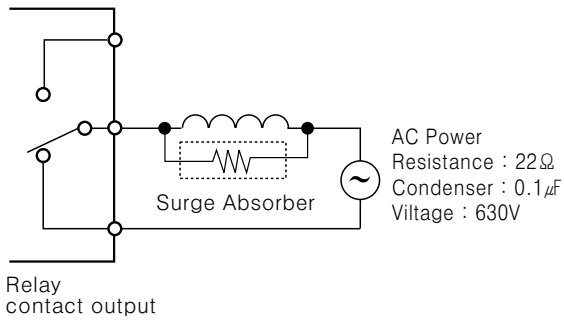

※ Max. revers voltage must be more then three time of load voltage
current capacity : 1A

Differential operation principle

◎Detection of the metal level

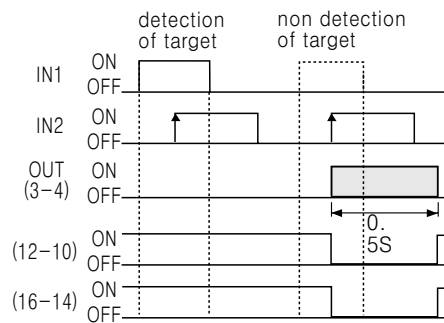
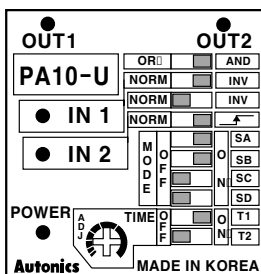
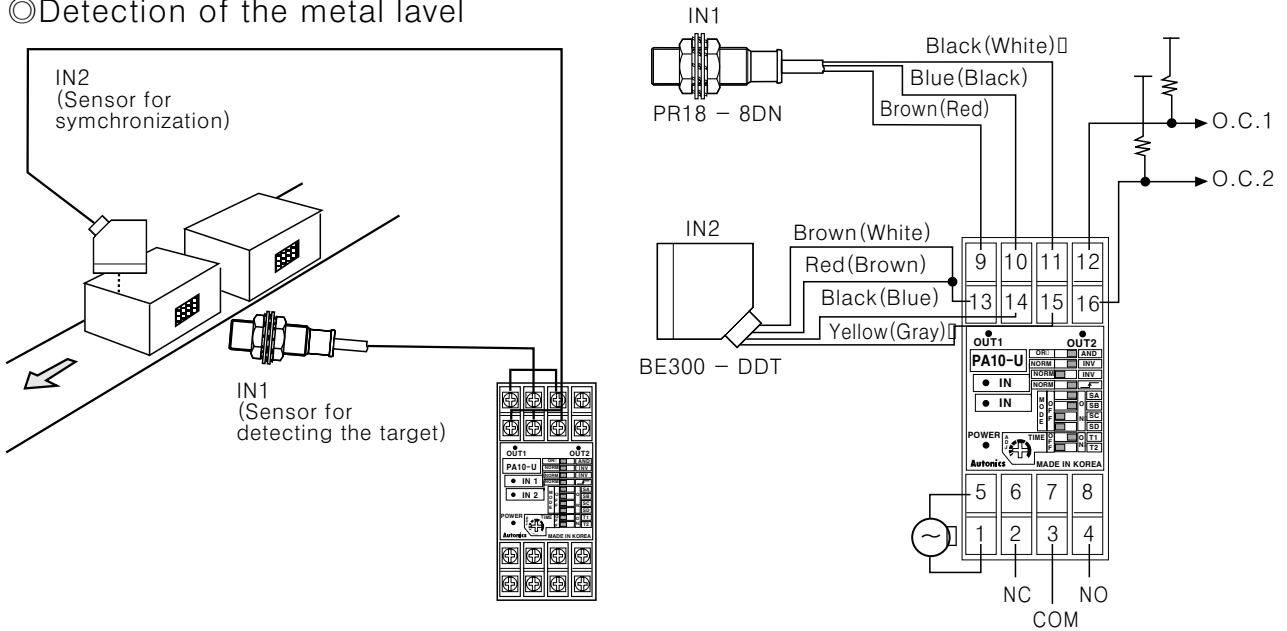

※ When IN2 (sincromized sensor) detects the target, IN1 turns on, and output turns off,
When IN2 do not detects the target, IN1 turns off, and output turns on for 0.5sec.

Parts name & function

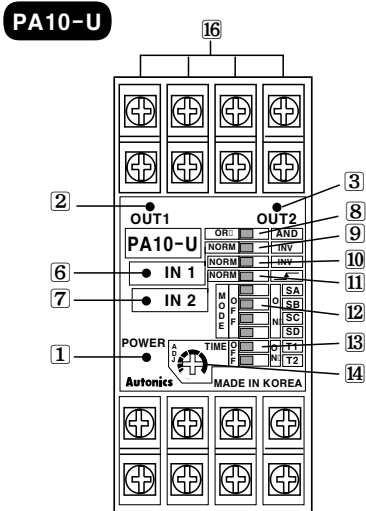

No	Parts name	Function
1	Power Indicator	Indicator turn on when AC power turns on
2	Output Indicator 1	Indication of output signal
3	Output Indicator 2	
4	——	
5	——	——
6	Sensor input (IN 1) Indicator	Indication of sensor input signal (Indicator turns on when sensor input is low)
7	Sensor input (IN 2) Indicator	Indication of sensor input signal (Indicator turns on when sensor input is low)
8	AND/OR Selection switch	Select "AND" or "OR" for IN1, IN2 Input
9	Selection switch of sensor input signal (IN1)	NORM <input type="checkbox"/> INV <input type="checkbox"/>
10	Selection switch of sensor input signal (IN1)	NORM : LED turns on when input signal is low. INV : LED turns on when input signal is high.

11	Differential operation selection of IN2 input signal (It work only OR/AND selection switch at AND)	NORM : IN1, IN2 input signal is on and output be come on  Differential operation of IN2 input signal. (*note : Differential operation principle)
12	Selection switch for operation mode	<ul style="list-style-type: none"> ●MODE 0 NORMAL : Non-timer function input signal is output ●MODE 1 ON-DELAY ●MODE 2 OFF-DELAY ●MODE 3 ONE-SHOT DELAY ●MODE 4 FLICKER ●MODE 5 FLICKER ONE-SHOT ●MODE 6 Low-Speed Detection ●MODE 7 High-Speed Detection ●MODE 8 FLIP-FLOP

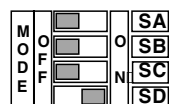
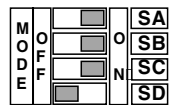
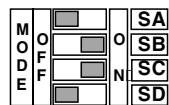
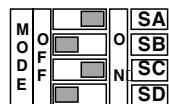
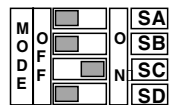
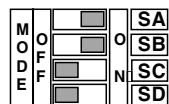
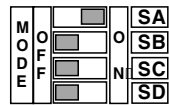
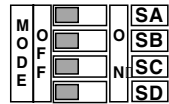

PA10-U

Parts name & function

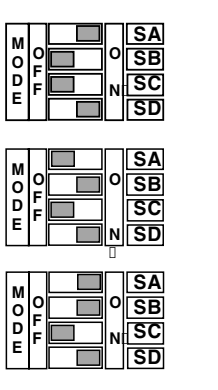
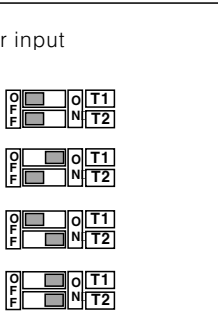
12	Selection switch for operation mode	<ul style="list-style-type: none"> ●MODE 9 ENCODER ●MODE 10 ENCODER ●MODE 11 ENCODER 	
13	Time range of timer & selection switch of MAX. response friquence	<p>Selection switch of time range (mode 1~7) or input frequency (mode 9~11)</p> <ul style="list-style-type: none"> ●Timer range : About 0.01~0.1sec ●MAX. response frequency : below 100KHz ●Timer range : About 0.1~1sec ●MAX. response frequency : below 10KHz ●Timer range : About 1~10sec ●MAX. response frequency : below 1KHz ●Timer range : About 10~100sec ●MAX. response frequency : below 100Hz 	
14	Timer volume	Adjust time as same as the range of NO.13 functuon	
15	_____	_____	
16	Terminal	_____	

SW setting value of PA10-U before making a shipment

: MODE1 ON-DELAY

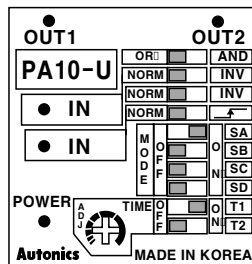

Countion for application in your line

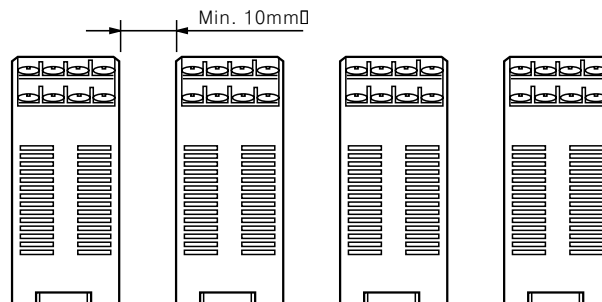

■ Operation

● AND FUNCTION

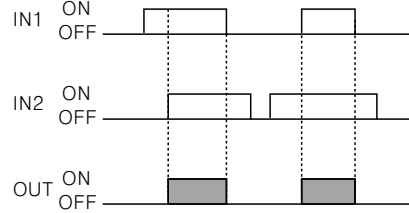
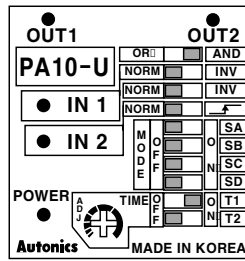

※ If both IN1 and IN2 turns on, output turns on.

● OR FUNCTION

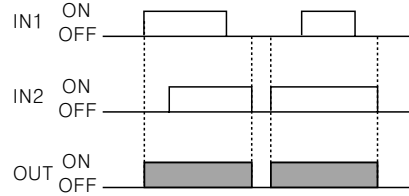
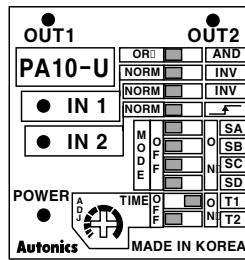

※ If one of IN1 or IN2 turns on, output turns on.

● MODE 1 ON-DELAY MODE

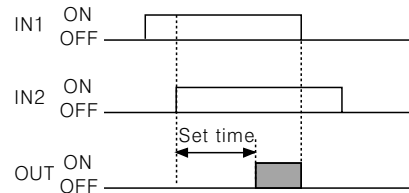
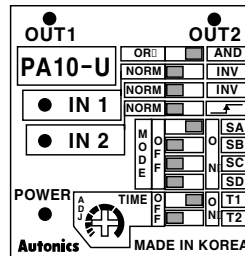

※ If both IN1 and IN2 turn off, output turns on after set time, output turns off, if IN1 and IN2 turn off, output turns off.

● MODE 2 OFF-DELAY MODE

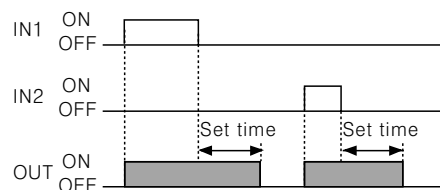
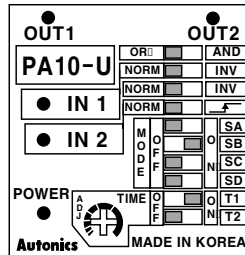

※ IN1 or IN2 is turns on, at the same time output also turns on, after IN1 or IN2 is turns off, The output turns off after set value.

● MODE 3 ONE-SHOT DELAY MODE

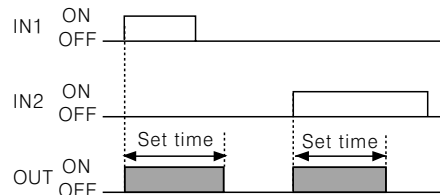
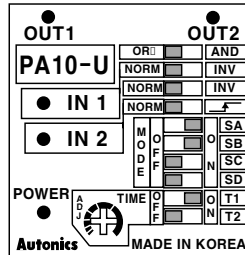

※ If IN1 or IN2 turns on, at the same time output turns on and turns off after set value.

● MODE 4 FLICKER MODE

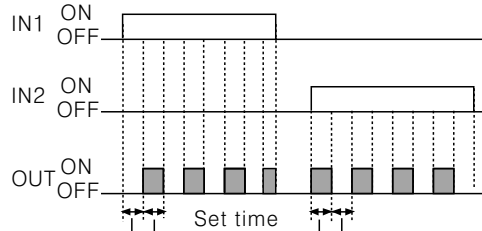
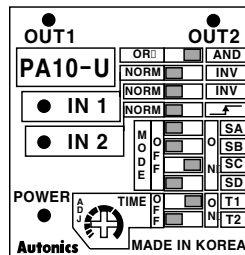

※ 1. Output flicker after output turns off as much as set time during on time of IN1.
2. Output flicker after output turns on as much as set time during on time of IN2.
3. ON/OFF duty rate is 1:1.

4. OR AND NORM IN Selection S/W is no mater to function.

Operation

●MODE 5 FLICKER ONE-SHOT MODE

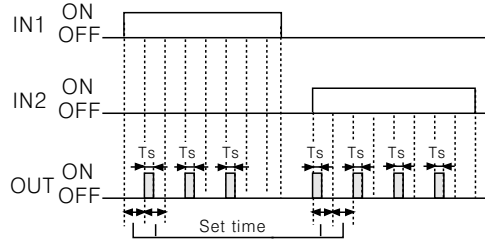
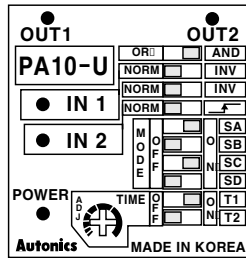

1. Set time(T_s) is selected by below selection S/W and the time range is as follow;

NORM F : T_s = about 10ms

NORM F : T_s = about 100ms

2. OR AND Selection S/W is no mater to function.

●MODE 6 LOW-SPEED DETECTION MODE

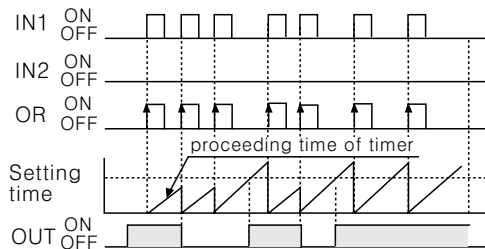
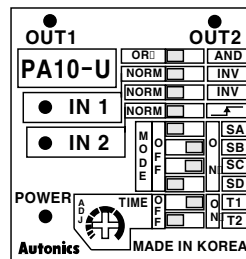

※ The output turns on when input cycle is longer than set time as comparing set time with each input cycle at the same time when the signal is inputted.

●MODE 7 HIGH-SPEED DETECTION MODE

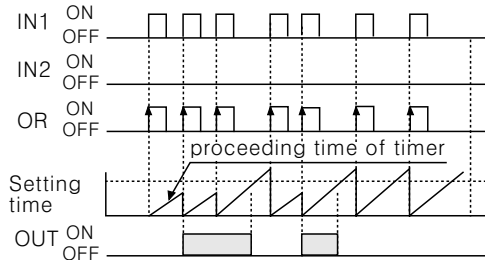
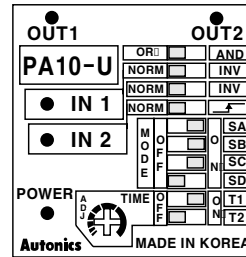

※ The output turns on when input cycle is shorter than set time as comparing set time with each input cycle at the same time when the signal is inputted. (This mode is opposed to low-speed detection mode)

※ Setting time of mode 7 & mode 8 must be set by front the adjster.

SW	Time□	Frequency	RPM(1pulse per 1revolution)
<input type="checkbox"/> T1 <input type="checkbox"/> T2	0.01 to 0.1 (sec)	100 to 10 (Hz)	6,000 to 600(RPM)
<input type="checkbox"/> T1 <input type="checkbox"/> T2	0.1 to 1 (sec)	10 to 1 (Hz)	600 to 60(RPM)
<input type="checkbox"/> T1 <input type="checkbox"/> T2	1 to 10 (sec)	1 to 0.1 (Hz)	60 to 6(RPM)
<input type="checkbox"/> T1 <input type="checkbox"/> T2	10 to 100 (sec)	0.1 to 0.01 (Hz)	6 to 0.6(RPM)

●MODE8 FLIP FLOP MODE

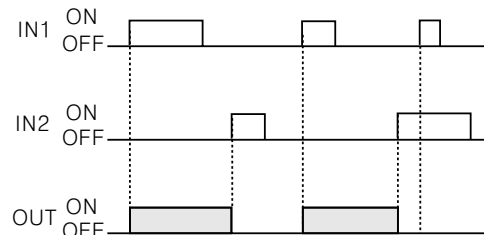
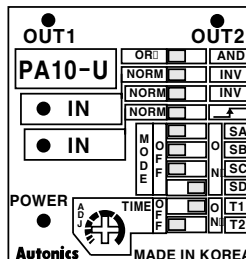

※1. FLIP-FLOP output turns on when IN1 turns on, output turns off when IN2 turns on.

2. Preperence of signal acceptance give IN2 frist.

3. OR AND Selection S/W is no mater to function.

■ Operation

◎ ENCODER MODE

● FOR INPUT

- 1N1 and 1N2 input must be the difference of phase of 90°.
- When encoder with output of NPN open collector or totem pole is connected PA10-U, the output of encoder A phase connect to 1N1, encoder B phase does to 1N2
(When encoder turn to clockwise, O.C.2 output of PA10-U turns off)
- OR AND, NORM INV, NORM selection S/W is no matter to function.

● For output

1. Encoder mood has the function of the multiple PULSE output as much as one time, two times, four times for encoder input signal and up/down(O.C.2).
(mode 9 encoder: multiply one time, mode 10 encoder: multiply two times, mode 11 encoder: multiply four times)
2. Pay attention for the input speed of the connected equipment due to the narrow output pulse width in output of O.C.1.

※ Encoder mode and output pulse signal width and response time.

SW	Encoder specification	Response time of equipment
	▶ Encoder output Frequency at 100KHz ex) 600P/R Encoder 10,000 RPM	2MHz Max. (2,000,000cps)
	▶ Encoder output Frequency at 10KHz ex) 600P/R Encoder 1,000RPM	200KHz Max. (200,000cps)
	▶ Encoder output Frequency at 1KHz ex) 600P/R Encoder 100RPM	20KHz Max. (20,000cps)
	▶ Encoder output Frequency at 100KHz ex) 600P/R Encoder 10RPM	2KHz Max. (2,000cps)

● MODE 9 ENCODER (INPUT PULSE × 1)

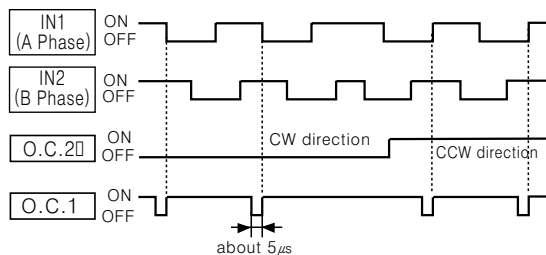
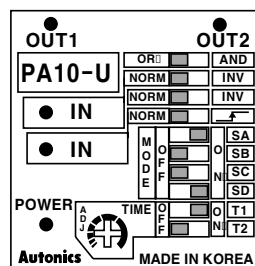

● MODE 10 ENCODER (Input pulse × 2)

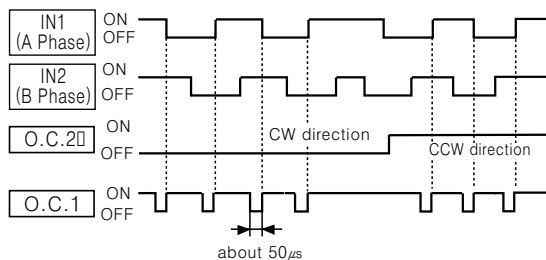
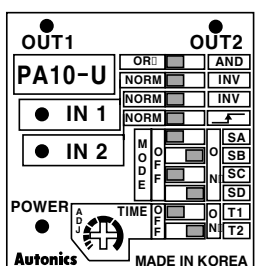

● MODE 11 ENCODER (Input pulse × 4)

